

Weirs

Revised: 9/25/2011 jcw

Purpose:

The purpose of this laboratory is to gain understanding of flow measurement devices in open channel flow.

Background:

Weirs are used to measure flow rates in open channels. In this laboratory exercise we will investigate the behavior of sharp crested weirs, broad crested weirs, and triangular (v-notch) weirs. The sharp crested weir is a simple device for measuring flow in canals and flumes. When atmospheric pressure prevails above and below the nappe, it is said to be well ventilated. The discharge equation is:

$$Q = K\sqrt{2g}LH^{\frac{3}{2}} \quad (1)$$

$$K = 0.40 + 0.05\frac{H}{P} \quad (2)$$

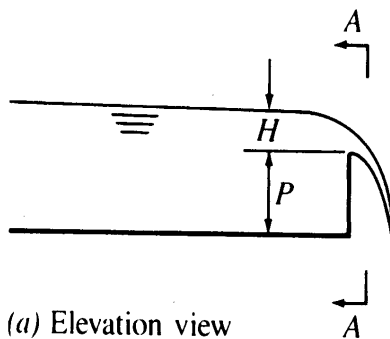

where units are ft and s. For low flow rates, triangular (v-notch) weirs can be used. The equation is given as (units: ft, s):

$$Q = \frac{8}{15}K\sqrt{2g}\tan\left(\frac{\theta}{2}\right)H^{\frac{5}{2}} \quad (3)$$

where K is about 0.585.

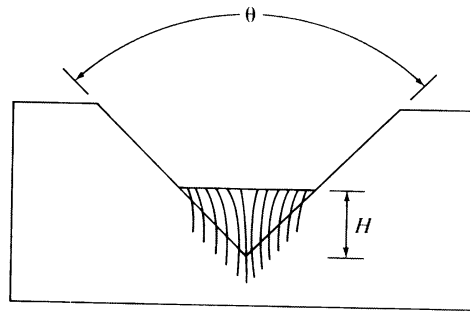

Figure 4-36 Triangular weir

Broad crested weirs have critical flow on the top giving a discharge equation of:

$$Q = CL\sqrt{g}\left(\frac{2}{3}H\right)^{\frac{3}{2}} \quad (4)$$

where C is given by:

$$C = \frac{0.65}{\sqrt{\left(1 + \frac{H}{P}\right)}} \quad (5)$$

The disadvantage of a broad crested weir is that it produces considerable head loss and sediment can build up upstream of the weir, affecting the flow and flow measurement. Venturi flumes were designed to eliminate these problems.

A sluice gate can be used to measure and control flow. The equation for flow is:

$$Q = KLy\sqrt{2gH} \quad (6)$$

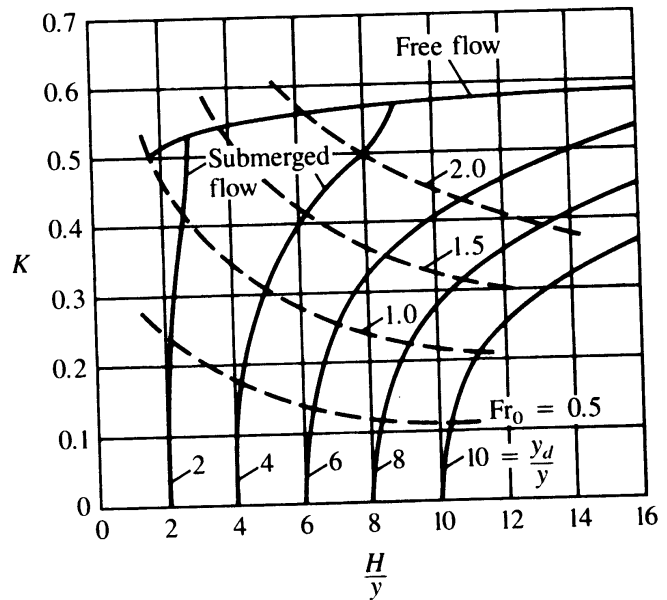
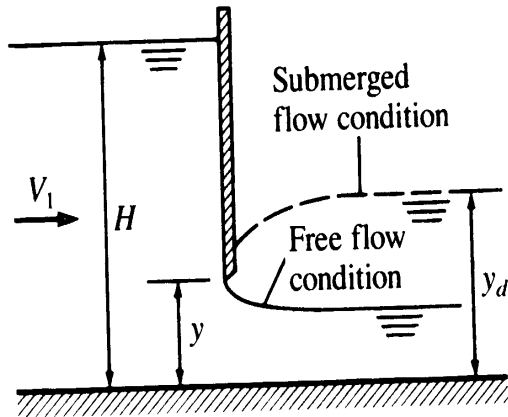

Method

- i Fill the flume with water and make the bed flat. Lower the tailgate.
- ii If possible, test two or more weirs at the same time. This gives a better comparison between them since the flow meter built into the flume is not accurate.
- iii Measure H (depth) for a wide range of discharges or water levels above the crest (at minimum of 6 points at increments of 0.5 inches or 12 mm should suffice). Record the respective flow by reading the flowmeter every 30 seconds (take the average). Ventilate the cavity beneath the nappe or jet of water within the cavity with a small diameter pipette as often as needed in order to prevent the cavity from decreasing the pressure thus affecting the discharge characteristics in the form of vibrations of the nappe. Measure water height versus flow rate for at least 6 different flow rates.
- iv take measurements for each of the 4 types of measurement devices

Analysis

- i Make 4 plots of H versus flow rate and perform a regression analysis to determine the appropriate power on H . Compare your results to the textbook equations used for each flow device.
- ii Make a plot of measured versus theoretical flow rates for each flow measuring device.